

Further Advancing the World Standard CNC from FANUC

FANUC

Series Oi-MODEL F



Further Advancing the World Standard CNC from FANUC

FANUC Series Oi-MODEL F

New Oi series CNC Provides Added Value to Machine Tools

Mach
Perform

- New LCD/MDI unit with new design
- Achieves both high accuracy and smoothness with easily adjusting steps
- Loader control commanded by G code meets the request of automation
- The FANUC platform adds the convenience of a PC



Minimizing
Downtime

Machining
Performance

High-Speed and High Quality Machining
Excellent Control Functions

- Nano CNC system combined with precise nano-calculation and leading-edge servo technology
- AI Contouring Control effective for high-speed and high precision machining
- Smooth Tolerance⁺ Control achieves high-quality machining
- Smart Overlap enables a shorter cycle time for machining parts
- SERVO HRV Control achieves high speed and precision
- SPINDLE HRV Control achieves fast response and high efficiency
- FANUC SERVO GUIDE for quick and smart tuning

Pursuing Ease of Use
Abundant CNC Functions and Operability

- Increasing the number of controllable axes makes it ideal for a wider range of machines
- 10.4 inch LCD/MDI display units with a new design available in addition to the 8.4/10.4/15 inch display units
- Loader is cost effective and easily configured with the new Loader Control function
- FANUC Platform enables the convenience of a PC in the CNC
- Support of various industrial networks and field networks
- Direct editing and operation of the CNC program on memory card

ining
mance

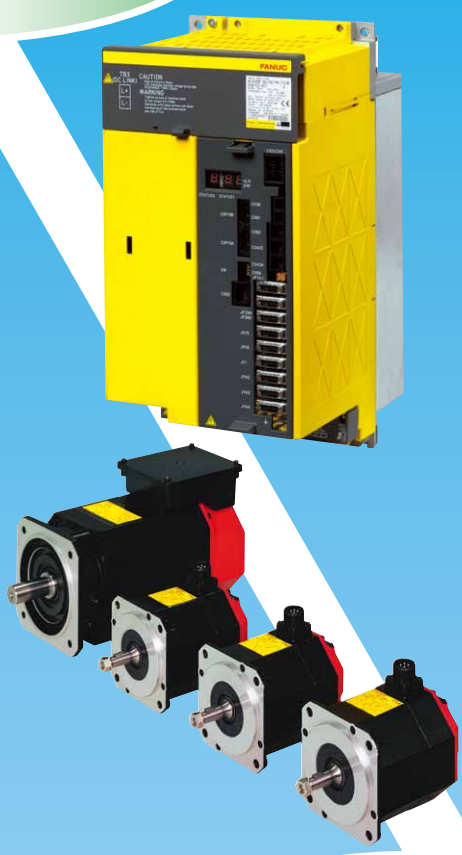

Ease of Use

Ease of Use

Seamless Functions with 30i-B series CNC

- Common screen and operability
- Common maintenance
- Common network functions
- Use of common peripheral devices
- Support of the same PMC functions

High Performance and Value

- Packaged with CNC functions in each type
- Ultra compact CNC with less-wiring and high reliability with leading-edge technology
- Providing the best solution with the combination of *βi* servo system

CNC Lineup

FANUC Series Oi-MF

CNC for Machining Center
 1 path system total controllable axes: up to 9 *1
 2 path system total controllable axes: up to 11 *1
 Simultaneous controlled axes : up to 4 axes

FANUC Series Oi-TF

CNC for Lathe
 1 path system total controllable axes: up to 9 *1
 2 path system total controllable axes: up to 12 *1
 Simultaneous controlled axes : up to 4 axes

FANUC Series Oi-PF

CNC for Punch Press
 1 path system total controllable axes: up to 7 *1
 Simultaneous controlled axes : up to 4 axes
 (* 1 : Total controllable axes is the sum of feed and spindle axes. Please refer to the specifications as for the specifications of each type, including the maximum values of feed axes and spindle axes.)

Minimizing Downtime

Focusing on Minimizing Downtime High Reliability and Easy Maintenance

- Highly reliable hardware allows stable operation in a harsh factory environment
- Failure prediction functions such as the leakage detection function achieve preventive maintenance, preventing long machine downtime
- Enhanced diagnosis and maintenance functions make it easy to identify failure locations and reduces time for recovery
- Improved maintainability achieved by the structure that allows for quick replacement of fans or batteries

ity

- Integrated Operation & Programming Guidance with extremely simplified operations
FANUC MANUAL GUIDE *i*
- Programming Guidance with various machining cycles
FANUC MANUAL GUIDE *oi*
- High-speed and large capacity PMC with Function Block function as standard and multi-path PMC
- Safety achieved by the Dual Check Safety embedded into CNC
- Customize functions for each unique machine
- Tuning functions help easily set-up machine tool

State-of-the-Art Hardware

Ultra-Compact, Reduced Wiring, High Reliability

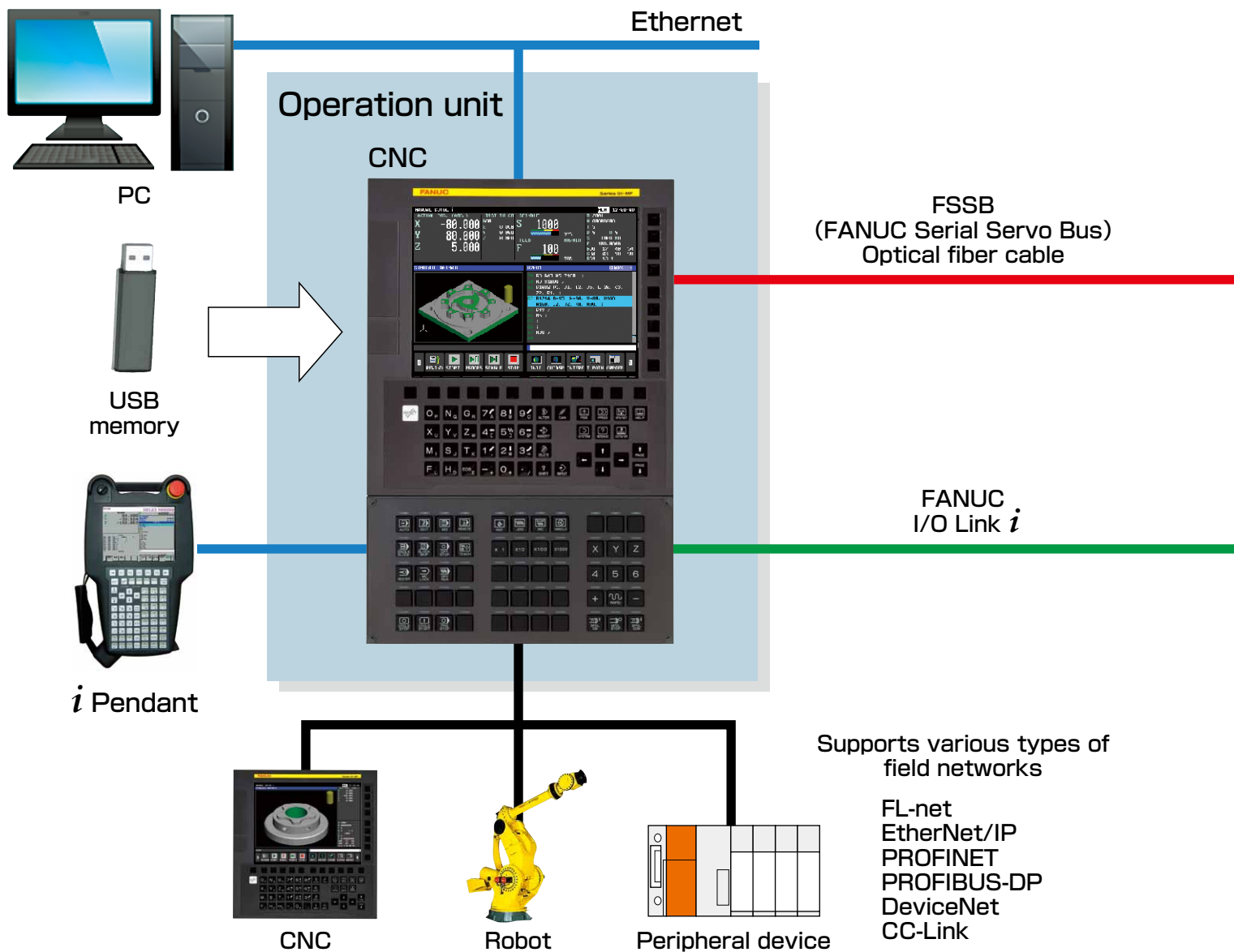

Thin and Compact CNC

Small sized CNC integrated with the LCD enables a compact operation unit. The depth of CNC is only 60mm (*1).

Each display unit size (8.4, 10.4, or 15 inch) accommodates machines of various sizes, from small to large.

(*1:8.4/10.4 inch display with no optional slot)

Enhanced Basic Performance

Basic performance of the CNC, servos and the PMC has been enhanced to achieve high-speed, high-precision, and high-quality machining, increased control axes, and high-speed control of the loader or peripheral equipment.

Reduced Wiring

Faster FSSB and FANUC *i* I/O Link realize further reduction of wiring and lower wiring cost.

Faster FSSB

CNC and the amplifiers are connected with FSSB (FANUC Serial Servo Bus) using optical fiber cable. High performance and reduced wiring are realized by optimizing communication protocol and ECC technology with the high-speed and high level noise tolerance by the optical fiber cable. In addition, spindle amplifiers can be now connected to FSSB.

FANUC *i* I/O Link

FANUC *i* I/O Link is a serial I/O interface between the PMC and various I/O units. In addition to general-purpose I/O units, the machine operator's panel or handy machine operator's panel can also be connected.

FANUC *i* I/O Link helps with quick recovery from trouble by making it easy to pinpoint the faulty part using various error detection capabilities such as bitwise DO ground fault detection and I/O power supply failure detection, etc. FANUC *i* I/O Link realizes Dual Check Safety with a single cable, although conventional systems require two cables.

Power magnetic Cabinet

SERVO
AMPLIFIER

β iSVSP-B series

SERVO
AMPLIFIER

α i-B series



I/O Unit



I/O module for
connector panel

AC SPINDLE MOTOR

α i-B series, β i-B series

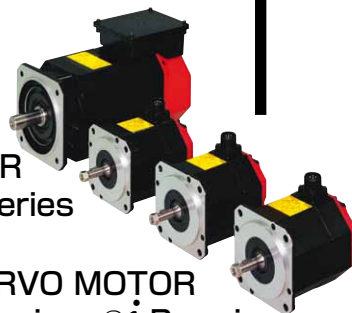

AC SERVO MOTOR

α i-B series, β i-B series

FANUC AC SERVO MOTOR

α i-B, β i-B series

High performance AC SERVO MOTOR for feed axis of machine tools

Smooth rotation and compact size
Quick acceleration
Small and high resolution PULSECODER
Excellent waterproofness
Bayonet type power connector
Reduced Backlash Brake
Line-up with both 200V and 400V input

FANUC AC SPINDLE MOTOR

α i-B, β i-B series

High performance AC SPINDLE MOTOR for spindles of machine tools

High power and high torque with compact size.
Fast response and high efficiency achieved by SPINDLE HRV Control
Improved machining performance achieved by the enhanced short-time rated output
Capable of performing balance correction in the rear part of the motor even after being connected to the spindle
Hollow shaft models which enable center-through-coolant available
Line-up with both 200V and 400V input

FANUC SERVO AMPLIFIER

α i-B, β iSVSP-B series

Compact and energy-saving SERVO AMPLIFIER that contributes to downsizing of the electrical cabinet

Achieves high speed, high precision and high quality machining through the high power and high precision current control
Preventive maintenance possible by detecting insulation deterioration of motors under cutting fluid environment
Quick replaceable fan motor from the front side of the amplifier
The trouble-shooting function can quickly find the causes of alarms
A wide line-up of multi-axis amplifiers and all-in-one amplifiers integrating servo and spindle
Machine protection at power failure is enabled by adding modules according to the purpose
Energy saving by utilizing the latest low loss power device
Line-up with both 200V and 400V input

Network Support Functions

The various Industrial Ethernet and field networks are supported in order to suit a variety of network environments in the factory.

Ethernet is supported as a basic function, and the CNC can be connected to a personal computer to transfer a variety of NC data.

iPendant

iPendant is a portable operating unit. It is possible to watch the CNC screen and operate the machines at a distant point from the main operator's panel. Moreover, touch panel and the manual pulse generator can be selected as an option.

High Reliability Realized by ECC

By applying the ECC (Error correcting code), it can automatically correct the error from electrical noise inside of the CNC. As a result, a highly reliable CNC is realized.

Easy Maintenance

Unexpected system downtime for a long period of time can be prevented by the function to detect and display signs of trouble that can lead to system down if ignored. Fans for cooling and battery are stored in a cartridge and can be replaced quite easily, and maintainability is enhanced.

Various alarm detection functions help reduce downtime by making it easy to pinpoint the faulty part.

High performance

High-Speed, High-Quality Machining

Fine Surface Technology

Fine Surface Technology is a collective term for CNC and servo control technologies that achieve high quality machining. Fine Surface Technology allows for the interpolation of high precision machining program output from CAD or CAM, high-speed execution of small segment programs, the generation of a smooth tool path and accurate command tracing.

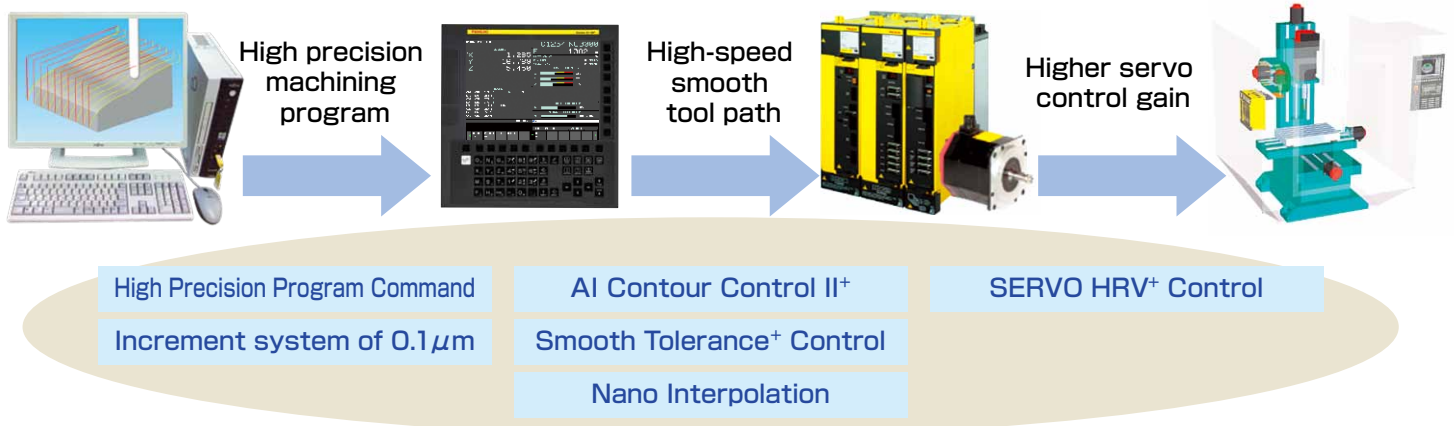

High precision program command

Supports high precision machining program output from CAD or CAM

High precision programs can be interpolated without changing the increment system of the CNC. This eliminates errors caused by rounding in the program command unit.

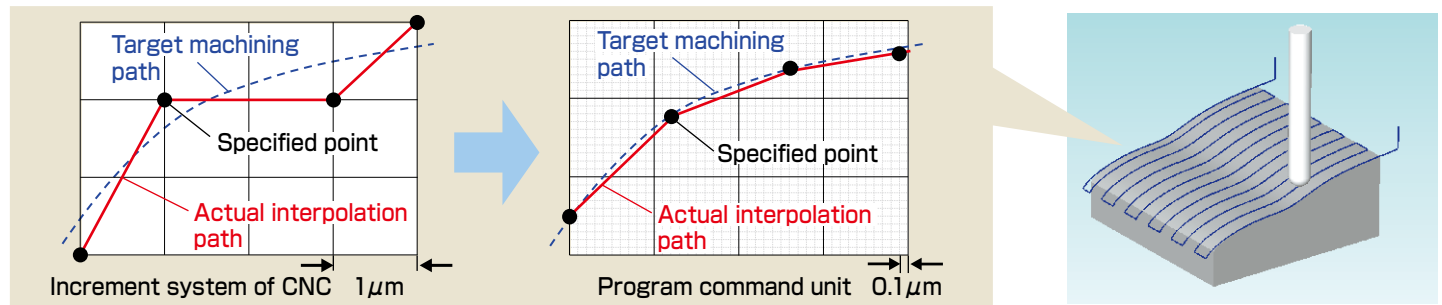

AI Contour Control I⁺ / AI Contour Control II⁺

Optimum the feedrate and acceleration control by reading blocks in advance

During the complex machining of aircraft or automobile parts, molds or other items that are specified as continuous small blocks, it is possible to determine the specified shape by reading program commands in advance, realizing control with a feedrate and acceleration optimal to the performance of the machine.

By analysing the machining program at a high speed, even small segment programs, which are required for high quality machining, can be executed at a high speed.



Smooth Tolerance⁺ Control

Smoothing continuous small blocks to realize high-quality machining

The machining path specified in continuous small blocks, like the one for mold machining, is smoothed out within the specified allowance error tolerance. The smooth machining path reduces mechanical shock and improves the quality of the machined surface.

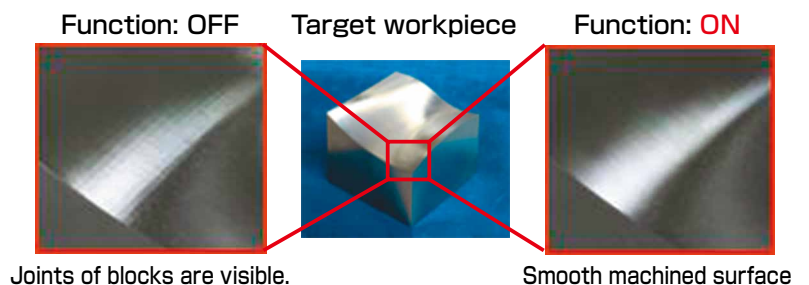

Advanced Digital Servo Technology

Smart Machine Control

Smart Machine Control is function group which achieves high-speed, high-precision, and high-quality machining by optimizing its control in real time according to changes of machine conditions such as load, temperature, and position.

Smart Spindle Acc/Dec

Selection of optimal common Power Supply

Smart Rigid Tapping

Reducing cycle time for tapping

Smart Thermal Control

Avoid over-heat caused by frequent acc/dec

Smart Load Meter

Best use of spindle performance

Smart Adaptive Control

Reducing cycle time for heavy cutting

Smart Feed Axis Acc/Dec

Auto-tuning of Acc/Dec time constant

Smart Overlap

Reducing cycle time

Smart Backlash Compensation

High-precision machining profile

Smart Machining Point Control

Suppressing machining point vibration

SERVO HRV Control

High-speed and high-precision servo control

By combining hardware technology and software technology such as the latest servo control HRV+, high-speed and high precision control with nano-meter level is ensured.

Mechanical resonance can be suppressed by the automatic following HRV filter even though its frequency changes.

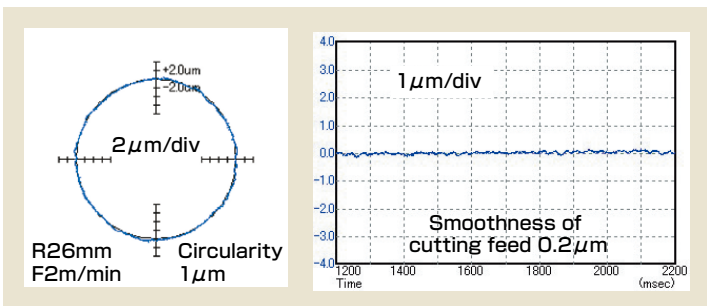

Application example of SERVO HRV+

SPINDLE HRV Control

High response and high efficiency spindle control

- Achieving high gain control and low heat generation at high-speed rotation by faster sampling time of the current control loop
- Optimum orientation for reducing cycle time by the optimum deceleration according to the inertia of workpieces or tools
- Supports Nano Interpolation in position control enabling Nano CNC system for spindle as well as feed axis

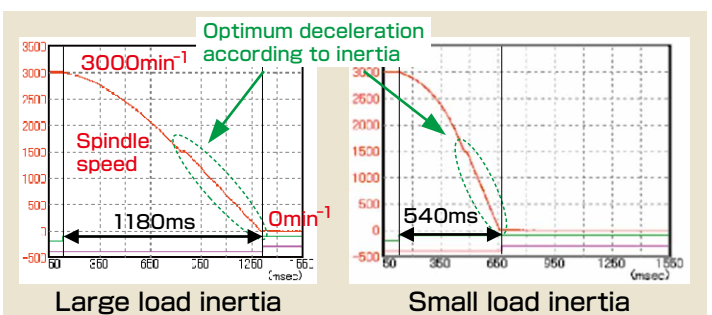

Optimum orientation (example)

Pursuing Ease of Use

Abundant CNC functions

Increase of CNC Functions

Increasing the number of controllable axes and paths makes it ideal for a wider range of machines.

- Extended axis number (from 8 axes to 9 axes) on 1 path system
- Increased number of axes (from 11 axes to 12 axes) (and spindles from four spindles to six spindles) on the 2-path system of *0i*-TF
- 2-path system is available on *0i*-MF
- No count Cs axis for number of feed axes, the number of controllable feed axes is increased

In addition to 8.4/10.4 display unit, larger 15 inch display unit is available.

By using the large display, the operability is further improved.

Enabling the commonly used and other various functions (program folder management of part program etc.) of 30*i*-B series, the usability of CNC system is further improved.

- Axis name expansion
- Program folder management
- Quick program restart
- 26 languages are supported
- Flexible path axis assignment
- Multi-path PMC function, Ladder Dividing Management function
- Main menu screen etc.

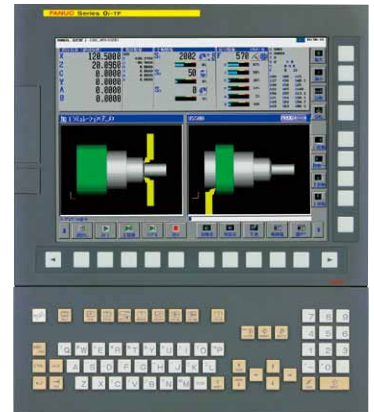

15 inch display unit

Function for Loader Control

Loader control can be easily achieved at low cost. This function can contribute to the automation of machine tools. Loader can be controlled by the same G codes as those of machining programs. There is no need to control an axis by the PMC ladder, etc. Loader programs can be executed independently of machining programs.

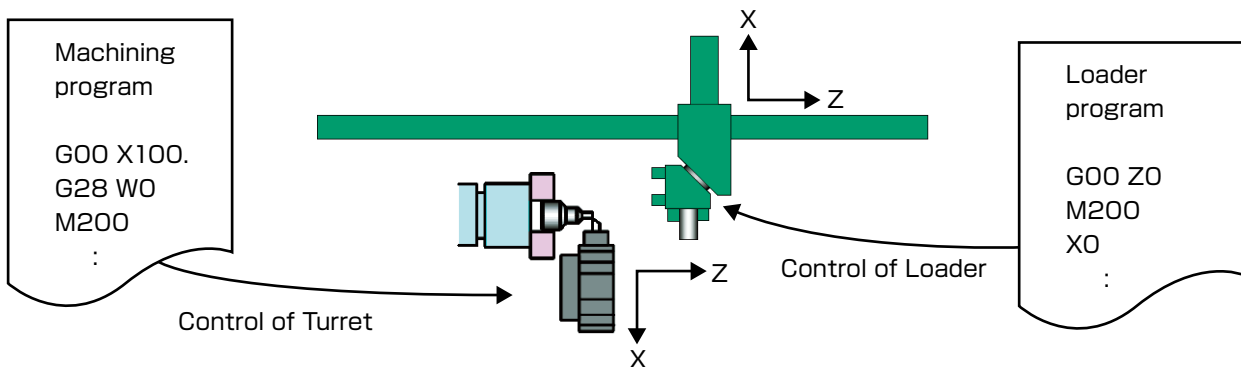

Set-up Guidance Function

Measurement is achieved by touching the tool to the work manually. And the measurement value can be set to the work coordinate system.

As a result, the arrangements time can be greatly reduced.

- Single surface measurement
- Outside diameter measurement
- Inside diameter measurement
- Outside width measurement
- Inside width measurement
- Measurement of corner outside
- Measurement of corner inside
- Angled work measurement



Support for adding sensors and peripheral devices

Multi C Language Executor

New custom screens can be easily added without changing the custom screens implemented in the machine (created with FANUC PICTURE or C language Executor).

Ladder Dividing Management Function

Ladders for controlling sensor or peripheral equipment can be added without changing the ladder for machinery control already implemented in the machine.

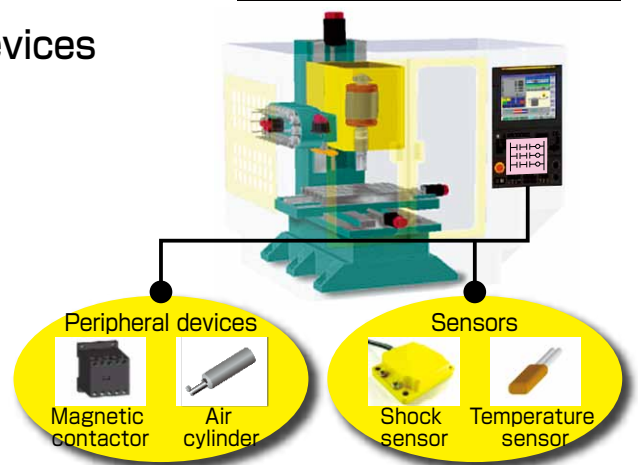

Excellent Operability

Ease of Use

FANUC Platform Provides Convenience of PC on CNC

Convenient platform with useful functions (e.g. high-speed graphics, large memory, etc.) can be added on CNC.

- Remote desktop function improves convenience of CNC by enabling operation of the PC connected via Ethernet from CNC. (e.g. operating the CAD/CAM, referencing the manual, etc.)
- Large program can be edited and operated with built-in large memory
- Web browser can be used

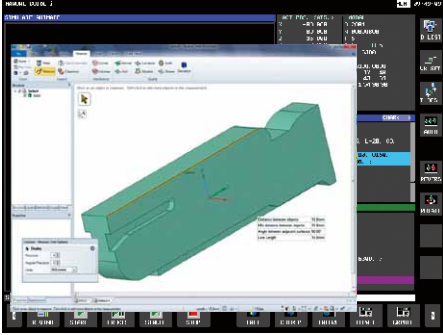

Remote desktop function
Operating the PC connected via
Ethernet from CNC

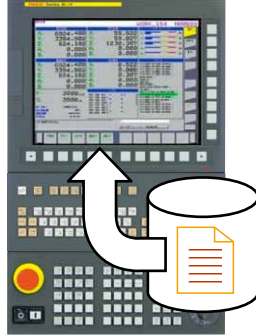

Memory operation
with large memory

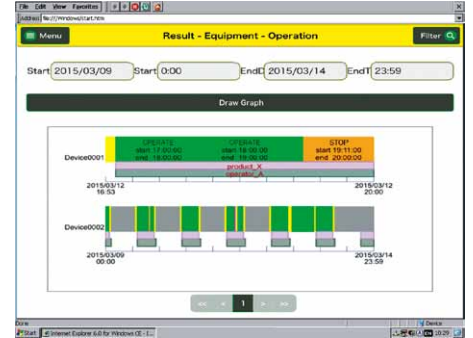

Web browser

Integrated Operation & Programming Guidance with extremely simplified operations

FANUC MANUAL GUIDE *i*

MANUAL GUIDE *i* is an integrated operation guidance, which provides easy operation guidance from programming through machine operation on one single screen. It can be used for lathes, milling machines and machining centers.

- Integrated operating screen
- ISO code part programming
- Powerful program editing functions
- Various machining cycles
- Realistic machining simulation
- Set-up guidance
- Multi-path lathe function

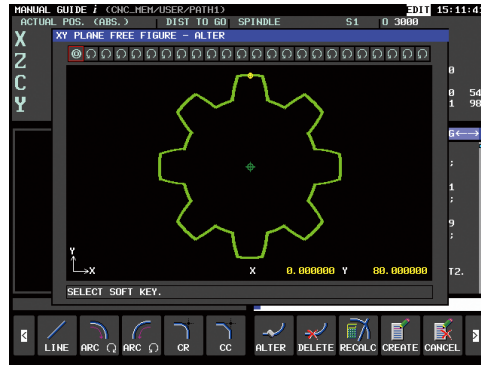

Free figure input screen

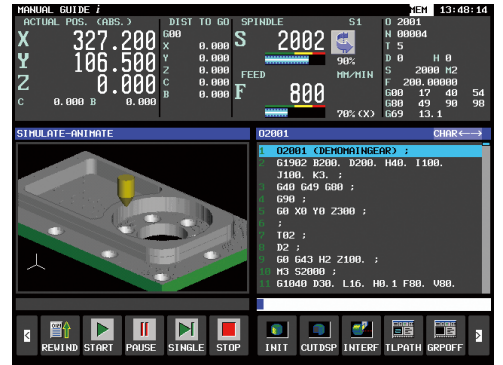

Machining simulation screen
(Scaling and rotation of animation)

Programming Guidance with various machining cycles

FANUC MANUAL GUIDE *Oi*

MANUAL GUIDE *Oi* is an easy to use part programming operation guidance function that simplifies the creation of a machining program. It is concentrated to the functionality of creating a part program and can be used for lathes, milling machines and machining centers.

- ISO code part programming
- G-code and M-code assistance
- Various machining cycles
- Contour programming

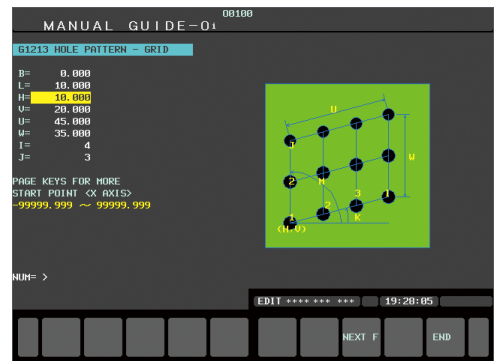
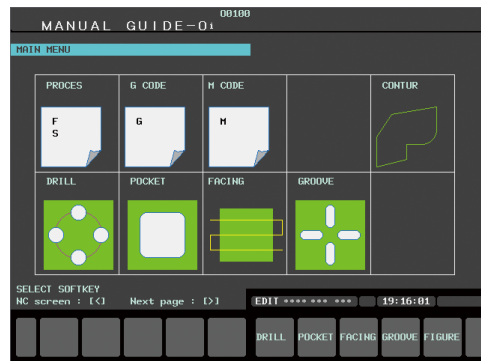

Network Support Functions

Ease of Use

With plenty of network functions, you can construct an optimum system for machine tools

Ethernet

Embedded Ethernet of 100Mbps is supported on the CNC main board. CNC can be connected to a personal computer to transfer NC programs and monitor CNC status.

The Fast Ethernet board can be mounted as an option. Data can be transferred simultaneously among multiple computers at high speed. These features are ideal to construct a production system which exchanges information among machining lines and factory host computer.

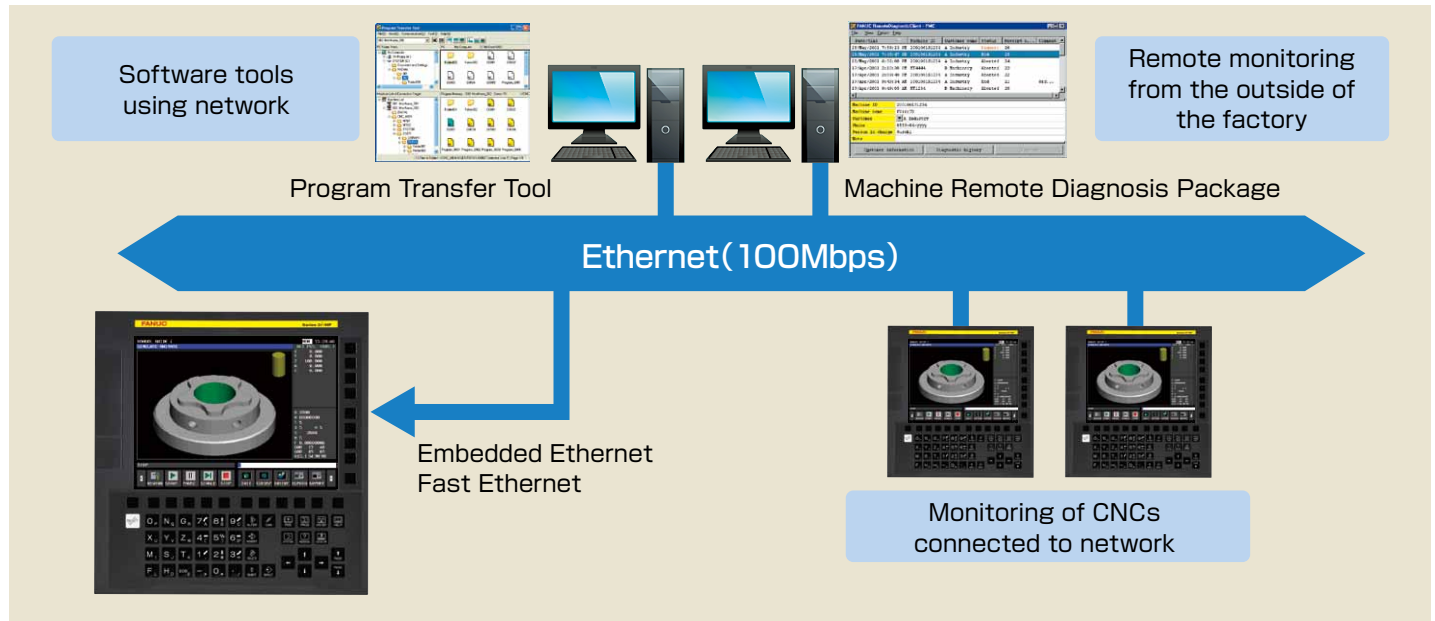

FANUC MT-LINKⁱ (Operation Management software) / FANUC OPC Server

This is a PC software that can manage the operational state of machine tools by connecting with them in the factory. It is suitable for the centralized control of the machine tools in the factory because the function to forward the processing program is provided. The collected data like the operation results can be accessed by the upper host system such as MES (Manufacturing Execution System).

Moreover, the PC software for the OPC server is prepared. This software can read and write the variable data between machine tools and the MES system with the OPC client function. The machine tools can be connected with the upper host system such as MES by using these software.

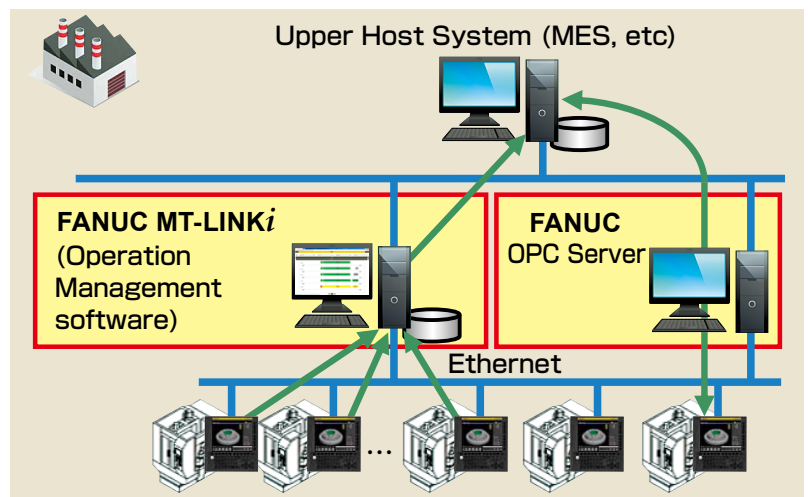

Industrial Ethernet / Field Network

The I/O signals of various peripheral devices such as waterproof equipment can be controlled and monitored by the ladder program.

Supports various networks

- FL-net
- EtherNet/IP
- PROFINET
- PROFIBUS-DP (Master/Slave)
- DeviceNet (Master/Slave)
- CC-Link (Slave)

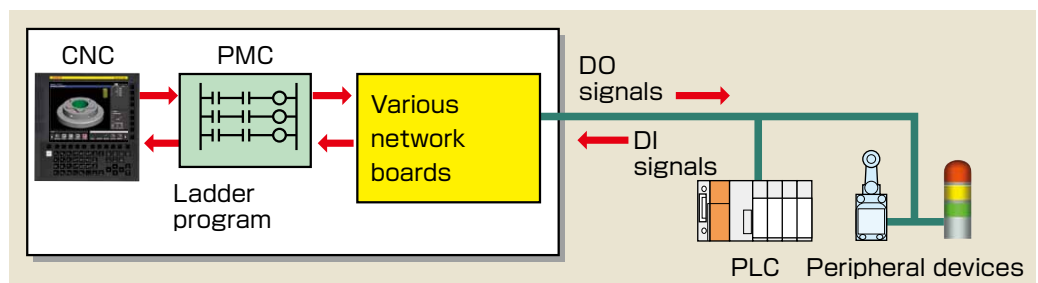

High-Speed, Large Capacity, and Multi-path PMC

High-Speed and Large Capacity

PMC becomes much faster. PMC, which consists of a dedicated processor and custom LSI, processes a large sequence of programs at a high speed.

- Program capacity Max. 100,000 steps (Total of all PMC paths)
- Internal relay (R) Max. 60,000 bytes
- Data table (D) Max. 60,000 bytes
- PMC paths Max. 3 paths (Max. 16 ladder programs)

Multi-path PMC

One PMC can execute up to 3 independent ladder programs. Each ladder program has an independent data area, which enables programs to be developed as independent modules. Ladder programs for loader and peripheral control can be created, added and modified separately. Ladder programs can easily be developed and the machine can easily be systematized according to each user's machine configuration. External PLC or other devices for peripheral control becomes unnecessary, which reduces system costs.

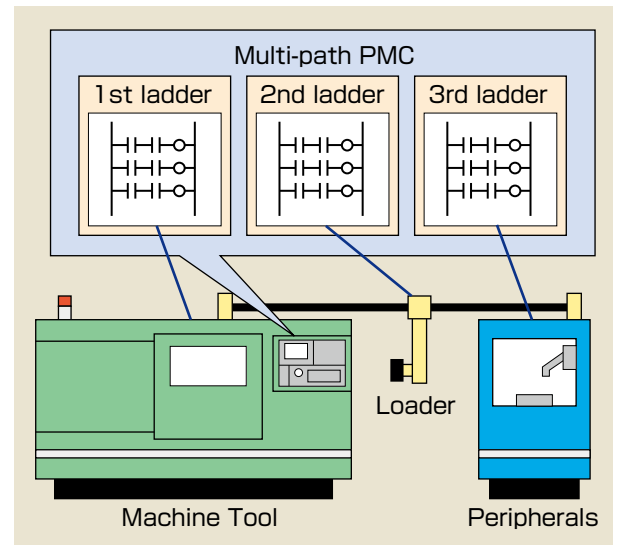

Function Block function (Basic function)

- This function enables to call up repeatedly used ladder circuit patterns in blocks.
- By combining multiple Function Blocks, machine tool builders can create complex ladder programs more efficiently, as if assembling components, with fewer steps for ladder program development and fewer ladder diagram drawings for maintenance.
- Many functions, such as PMC axis control and peripheral equipment control, are provided by customizable function blocks as PMC Function Library in FANUC LADDER-III's CD.

(Note: Function block does not have an effect on reducing the total program size.)

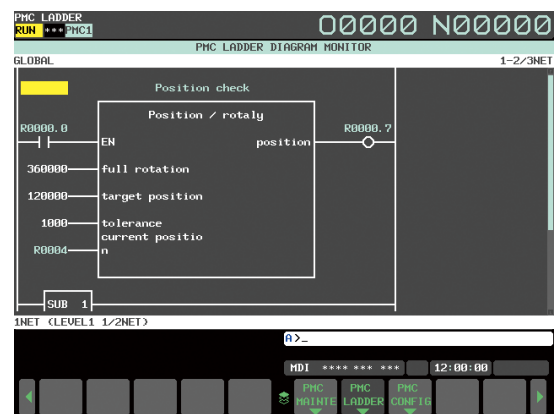

Function Block function

Safety Function

Dual Check Safety + Servo STO

Dual Check Safety is a safety function that conforms to the international safety standard (ISO 13849-1 PL d). This function offers a high level of safety by redundant monitoring, and by providing duplicate paths of breaking power for the servo/spindle amplifier. Safety functions built into the CNC make it easier to conform to the safety standards for machine tools.

- Cost can be reduced by significantly simplifying additional circuits for adherence to the safety standard.
- Two PMC functions have been incorporated into the CNC to duplicate sequence control for safety-related input/output signals.
- Safety-related input/output that is defined by a MTB allows redundant monitoring for controlling peripheral devices.
- By using FANUC I/O Link *i*, 1 channel I/O Link cable can configure safety function.
- The safety machine operator's panel which can make the key signals a safety-related signal is prepared.
- The Safe Torque Off (STO) function is incorporated in the servo amplifier. It is no longer necessary to install a magnetic contactor in the power line between the servo amplifier and the motor in order to shut the motor off.

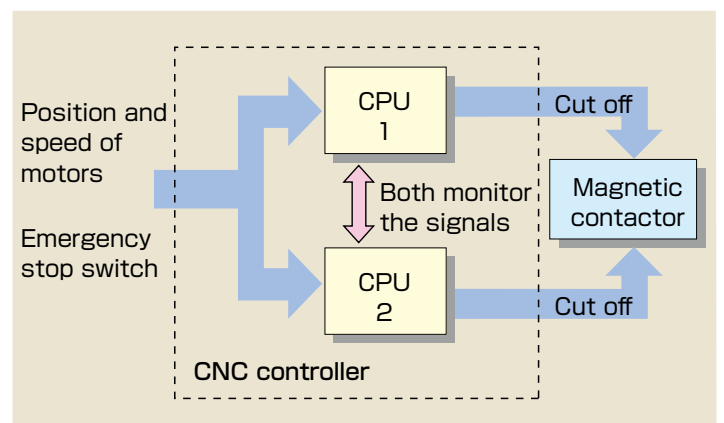

Many Customizable Functions

Ease of Use

Customizable functions are available, which allow machine tool builders to customize their own machine tools

Customizing operation screens	➔	C Language Executor/ FANUC PICTURE
MCN operator's panel is realized by softkey	➔	Machine operation menu function
Implementing original sequence control based on PMC	➔	FANUC LADDER-III

C Language Executor

Machine tool builders can create their own operation screens, which enables unique CNC display and operation.

- C language is used for programming.
- Multi window display enables creation of pop-up menus.
- Operation screens using the touch panel can be created.
- In addition to standard ANSI functions, many functions are available for CNCs and PMCs.
- High-level tasks to which high execution priority is assigned can monitor signal and position information.



FANUC PICTURE

FANUC PICTURE enables a machine operation screen to be created only by pasting screen components such as buttons and lamps on the personal computer.

- Easy-to-use interface unique to FANUC.
- A screen usable on a display unit with or without a touch panel can be created.
- A screen usable on a 15 inch display unit and with vertical soft keys can be created.
- A created screen is executed by the C language executor, and can coexist with a C language executor application created by a machine tool builder.

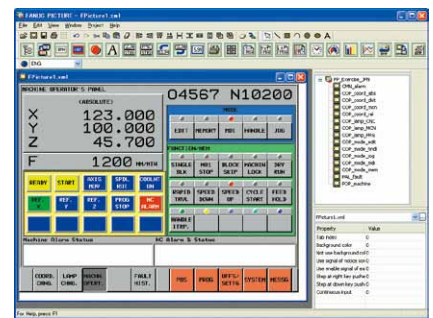

Machine Operation Menu Function

The softkey displayed on CNC screen can be used as a button to operate the machine.

Machine operation such as turning on or off the coolant, that is usually done with the machine operation board, can be done with a softkey on the CNC screen instead.

- The vertical softkey or horizontal softkey is used as a machine operation menu key.
- The hierarchy of the machine operation menu and the displayed character string can be set easily with a special tool on PC.

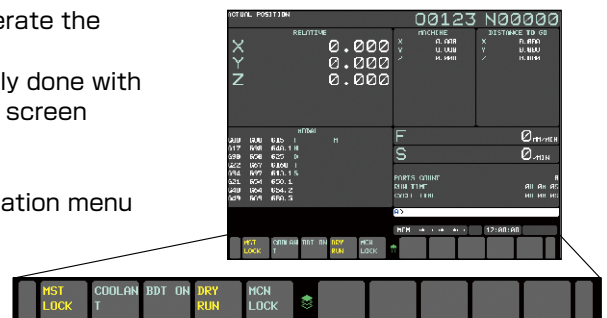

FANUC LADDER-III

For machine customization, a machine tool builder's own sequence control can be incorporated into the built-in PMC. A PMC sequence program can be created on a personal computer by using FANUC LADDER-III, a very easy-to-use programming tool with many useful functions.

- A program can be created with ladder and function block.
- A program can be coded using signal names instead of signal addresses.
- Online monitoring and editing can be performed by connecting a personal computer with the CNC via Ethernet.
- Including PMC Function Library which enables you to integrate functions such as PMC axis control easily.

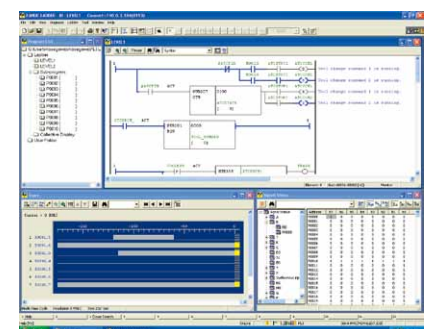

Powerfully supports setup and tuning of the CNC system

Easy CNC Startup

Automatic tuning of servo axes gain and filter

The recommended parameters for the CNC and servo axes for achieving high-speed and high-precision feed can be set by the CNC Startup Tool. Sufficient precision can usually be achieved by this setting. When even higher precision is required, the filter to eliminate machine resonance and optimum velocity gain suitable to the machine characteristics can also be set automatically by only pressing the soft-key for parameter tuning.

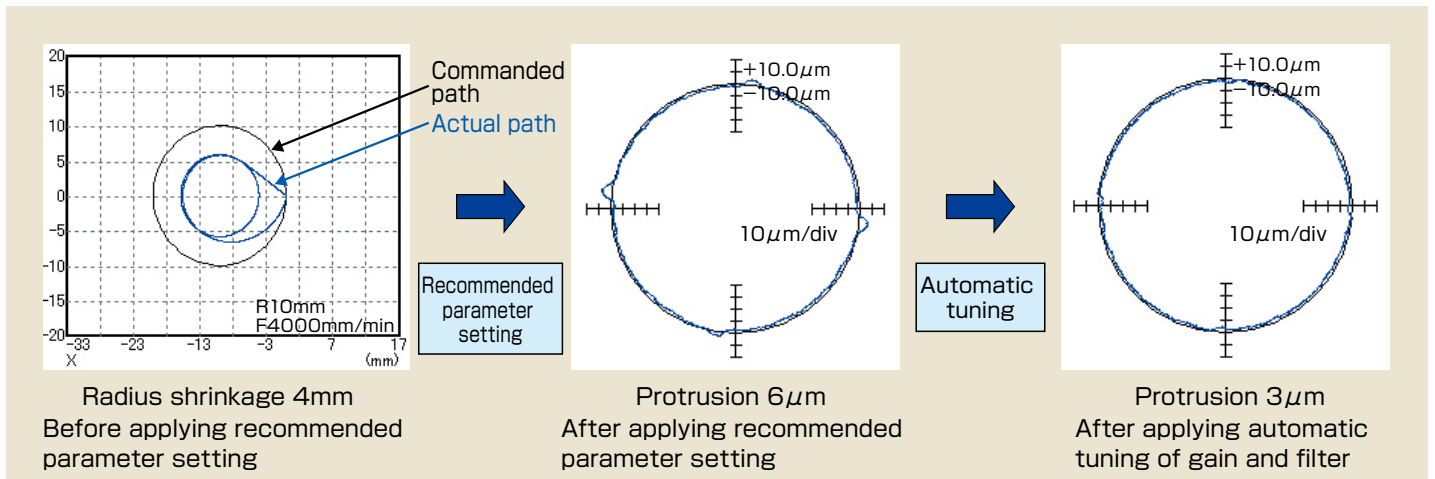

Easy Setting of Machining Conditions

Because standard setting values are provided for each machining process (roughing, semi-finishing and finishing), parameters that affect high-speed high precision machining can be set and tuned for each machine, with easy-of-operation enabled by the intuitive slide bar. During machining, you can select the process by using the machining program or screen operations to perform the machining under optimal conditions.

Setting

Parameter values recommended by FANUC can be set by simple operations.

Selection

Select the settings suitable for the machining process and perform machining.

Tuning

Easy and intuitive tuning is possible. Tuning for each machine is also possible.

	ROUGHING	SEMI FINISH	FINISHING
ACC FOR BIPL (mm/sec ²)	4800.000	*2000.000	1600.000
ACC CHG TIME(BELL) (msec)	15	32	48
MAX ACC (mm/sec ²)	*3000.000	*1500.000	1200.000
T-CON RIPL ACC/DEC (msec)	24	16	16
CORNER FEED DIFFER (mm/min)	*500.000	*500.000	400.000
TOLERANCE (mm)	0.020	0.010	0.005

If you change value without tolerance, the tuning value is set to 0.

ACCELERATION RATE FOR ACC/DEC BEFORE INTERPOLATION IN AT CONTOUR CONTROL ARE SET.
No. 1668

Roughing

Semi-finishing

Finishing

EASY TUNING

ROUGHING: +10 -25 to +25

SEMI FINISH: +5 -25 to +25

FINISHING: 0 -25 to +25

[TUNING MONITOR]

RECOMMENDED VALUES ARE TUNED IN PATTERNS. WHEN VALUES ARE TUNED TO (+) DIRECTION, MOTION BECOMES FAST.

Set parameter values for three patterns

Roughing
Semi-finishing
Finishing

Easy tuning using the cursor keys

Functions for minimizing downtime

Contribution to Preventive Maintenance

Leakage Detection Function

Insulation deterioration sometimes causes a machine to stop due to cutting fluid infiltrating the motor, especially in a severe machining environment. The leakage detection function built into the amplifier automatically measures the insulation resistance of the motor, and detects insulation deterioration in progress before it leads to machine downtime, enabling preventive maintenance.

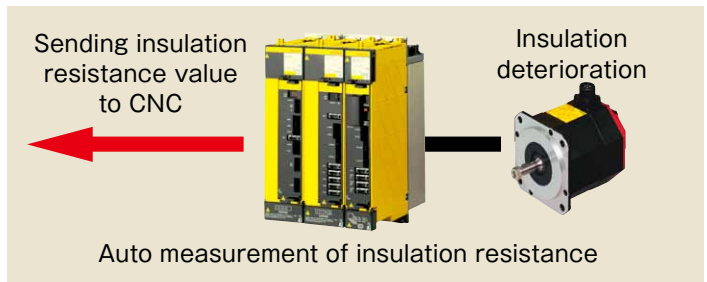

Cooling Fan Warning Function

By monitoring a decrease in the rotational speed of each cooling fan motor of the CNC and the servo amplifier, signs of fan abnormalities can be detected. This function enables preventive maintenance. Fans are stored in a cartridge and can be replaced quite easily, so maintainability is enhanced.

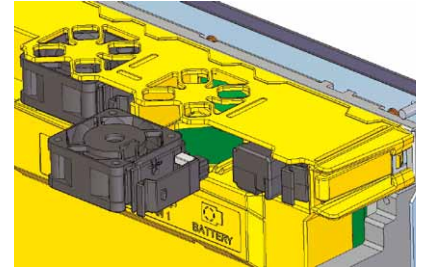

Failure Part Detection

Trouble Diagnostic Function

Various failure detection functions provided to the I/O Link *i* and FSSB can detect interruptions in the power supply to the I/O modules or servo amplifier and identify disconnection locations of the communication cable. In addition to that, I/O Link *i* can detect the ground fault of each DO.

The trouble-shooting function enables you to see diagnosis information helpful in determining the status when an alarm occurs on the CNC screen.

- Trouble-shooting guidance screen
- Trouble-shooting monitor screen
- Trouble-shooting graph screen

Encoder Communication Check Circuit

If the detector encounters a communication error, which detector, feedback cable or servo amplifier has failed can be identified by using this check circuit for a quick recovery.

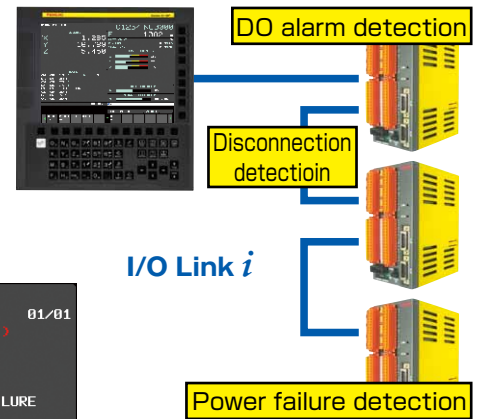
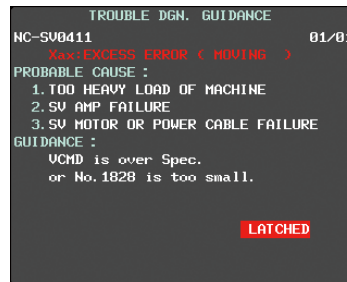

Protecting Machine at Power Failure

Machine Protection at Power Failure

Damage of workpieces and tools at power failure is prevented where a stable power supply cannot be expected.

- Gravity-axis drop prevention
The circuit incorporated in the amplifier detects power interruption and quickly activates the gravity axis brake.
- Stop distance reduction *1)
Feed axes are decelerated to stop in order to prevent them from crashing in high-speed machine tools.
- Retract *2)
Tool is retracted from workpiece keeping synchronization with gear cutting machine.

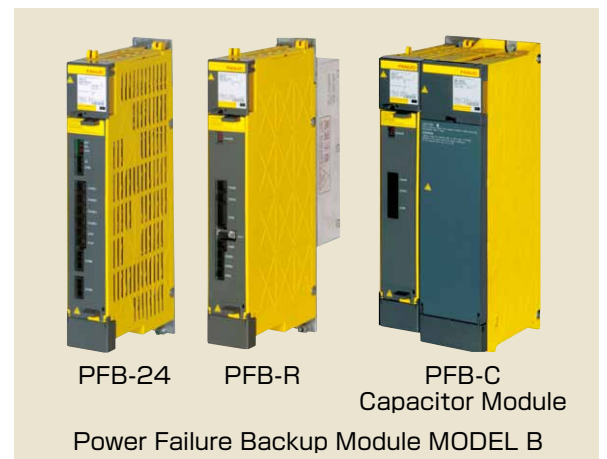

*1), *2) "Power Failure Backup Module (Hardware)" or "Power Failure Backup Function (Software)" shall be applied.

Powerful Software Tools

Supports development of machine tool builders in a variety of fields such as simulation and data management

FANUC NCGuide

Software tool "FANUC NCGuide" which simulates CNC operations on a PC to fully utilize the ever advancing CNC functions. The software tool can be used for development and educational purposes.

- NCGuide
- NCGuide Education Package

NCGuide

Development and debugging custom screens and ladder programs can be effectively performed on the PC. Because you can actually debug on a PC in the office before changing the customized software for the actual machining tool, it will improve efficiency of development work.

- FANUC PICTURE
Check operation of the operation screen created with FANUC PICTURE on the NCGuide
- C Language Executor
C language program for CNC is compiled for the PC and operation is checked on the NCGuide
- PMC Simulation
Simulation of the ladder program performed on the PC
Supports various functions such as Multi-path PMC and Function Block

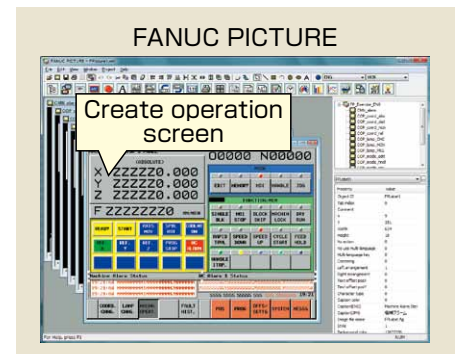

NCGuide Education Package

Can perform operation training of CNC/MANUAL GUIDEⁱ on the PC. It is possible to train operation without using the actual machining tool. We provide material for classroom use for 16/32 students and self-study at home for 1 or 3 years.

- Operation in MEM and NC mode/Automatic operation
- Editing the machining program and machining cycle in EDIT mode
- Use of macro variables and system variables
- Operation by calling sub-program and DNC
- Displays the same alarm as the machine at the time of error
- Machining simulation (cutting animation, tool path drawing)

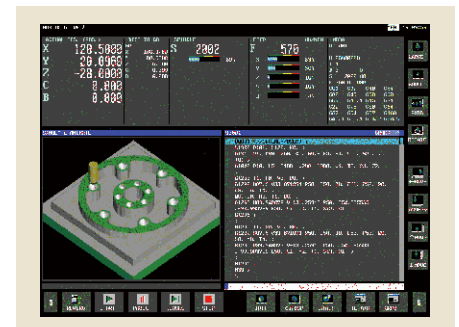

FANUC Program Transfer Tool

FANUC Program Transfer Tool is a software tool for transferring part programs and data by connecting PC and CNC via Ethernet. Files in the CNC program memory are displayed on the tool in an easy-to-understand way, so input/output operation can be easily performed with a mouse.

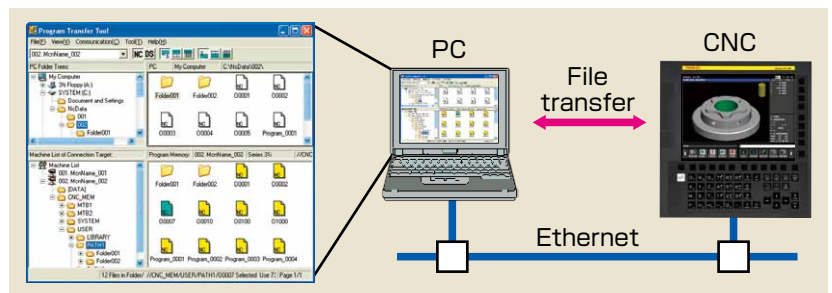

FANUC SERVO GUIDE

Support of efficient servo tuning for high-speed and high-precision machining

FANUC SERVO GUIDE allows you to perform tuning of the servo and spindle, including creating test programs, setting parameters and measuring data in an integrated manner. This PC software directly connects a PC and the CNC and is easy to use. In addition to the motions of each servo axis and spindle axis, you can observe program execution status inside the CNC and PMC signals as waveform data and analyze the machine operation in detail. FANUC SERVO GUIDE also supports continuous measurement for long periods.

The Tuning Navigator tunes gain, filter and other servo/spindle functions automatically, allowing advanced servo tuning to be quickly completed. The automatic tuning function for protrusion compensation significantly reduces the time for high-speed and high-precision tuning.

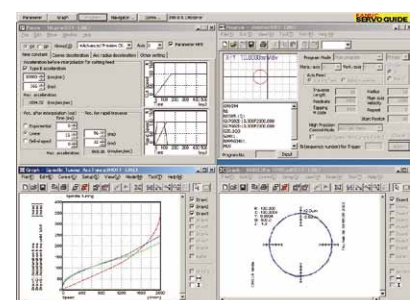

Maintenance and Customer Support

Worldwide Customer Service and Support

FANUC operates customer service and support network worldwide through subsidiaries and affiliates. FANUC provides the highest quality service with the prompt response at any location nearest you.

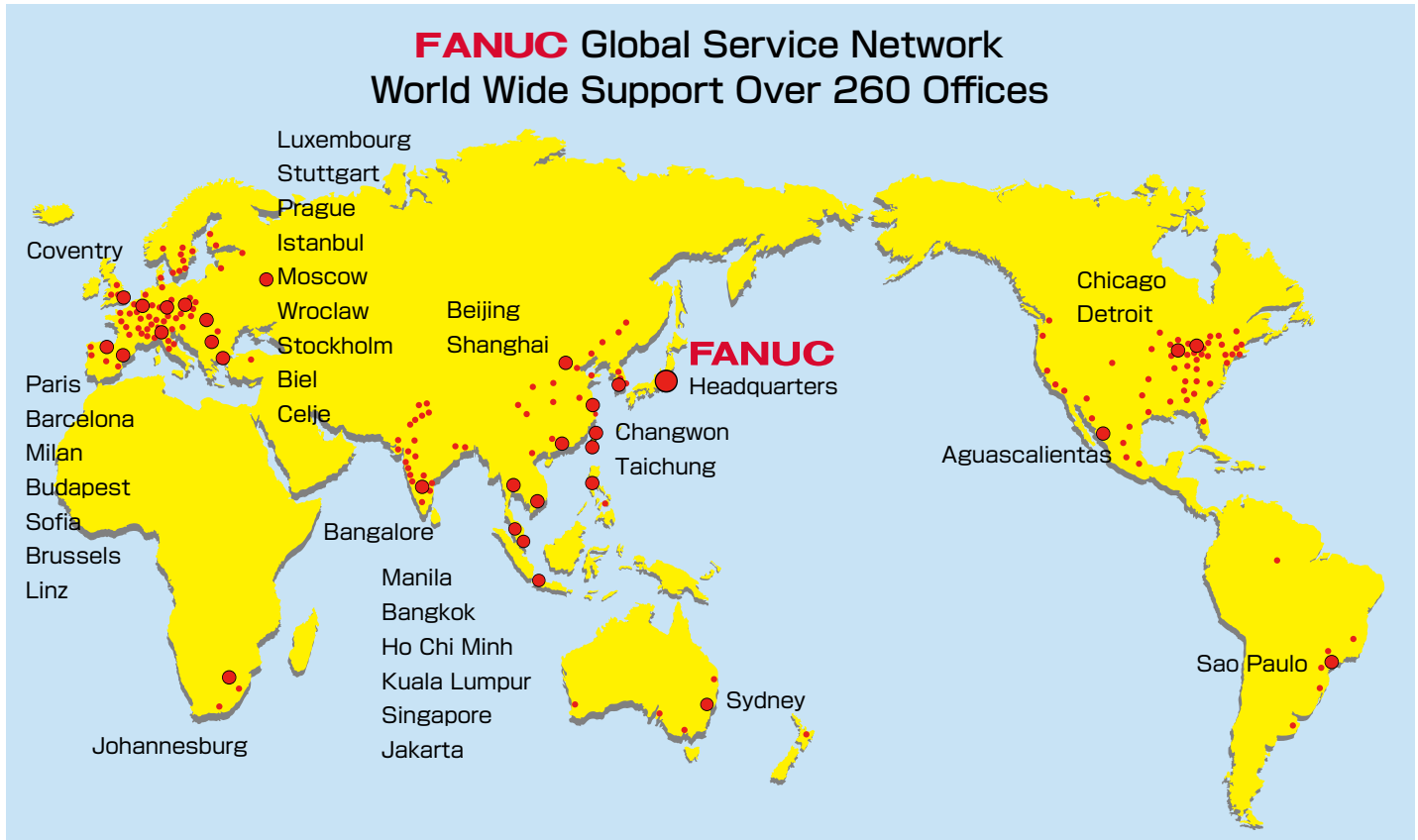

FANUC ACADEMY

FANUC ACADEMY operates versatile training courses to develop skilled engineers effectively in several days.

Inquiries : Oshino-mura, Yamanashi,
Japan 401-0597

Phone : 81-555-84-6030
Fax : 81-555-84-5540



FANUC CORPORATION

•Headquarters Oshino-mura, Yamanashi 401-0597, Japan
Phone: 81-555-84-5555 Fax: 81-555-84-5512 <http://www.fanuc.co.jp>

FANUC America Corporation
1800 Lakewood Boulevard,
Hoffman Estates, Illinois 60192, U.S.A
<http://www.fanucamerica.com/>

KOREA FANUC CORPORATION
101, Wanam-ro(st), Seongsan-gu, Changwon-si,
Gyeongsangnam-do, 642-290 Republic of Korea
<http://www.fkc.co.kr/>

FANUC Europe Corporation, S.A.
Zone Industrielle, L-6468 Echternach,
Grand-Duché de Luxembourg
<http://www.fanuc.eu/>

TAIWAN FANUC CORPORATION
No.10, 16th Road, Taichung Industrial Park, Taichung, Taiwan
<http://www.fanuctaiwan.com.tw/>

BEIJING-FANUC Mechatronics CO., LTD
No.9 Xinxu Road, Shangdi Information Industry Base,
Haidian District, Beijing CHINA 100085
<http://www.bj-fanuc.com.cn/>

FANUC INDIA PRIVATE LIMITED
41-A, Electronics City, Bangalore, 560 100, India
<http://www.fanucindia.com/>

• All specifications are subject to change without notice.
• No part of this catalog may be reproduced in any form.
• The products in the FANUC Series 0i-MODEL F listed in this catalog are not subject to Items 2 to 15 in the Attachment to the Foreign Exchange Order of the "Foreign Exchange and Foreign Trade Law" but are subject to Item 16 (catch-all controls).
The export from Japan may be subject to an export license by the government of Japan.
Further, re-export to another country may be subject to the license of the government of the country from where the product is re-exported. Furthermore, the product may also be controlled by re-export regulations of the United States government.
Should you wish to export or re-export these products, please contact FANUC for advice.